

NORMAL

MWO effective date 1 June 1992 and completion date 30 May 1994

MWO 9-2320-279-20-8

MODIFICATION WORK ORDER

**MODIFICATION OF M983 HEAVY EXPANDED
MOBILITY TACTICAL TRUCK (HEMTT) TRACTOR**

**INSTALLATION INSTRUCTIONS FOR
NATO SLAVE CABLE RETENTION DEVICE**

MODEL
TRUCK, TRACTOR WIWINCH W/O CRANE M983

NSN
2320-01-097-0247

HEADQUARTERS, DEPARTMENT OF THE ARMY, WASHINGTON, DC

1 JULY 1992

REPORTING OF ERRORS AND RECOMMENDING IMPROVEMENTS

You can help improve this MWO. If you find any mistakes or if you know a way to improve the procedures, please let us know. Write a letter, or complete and mail in a DA Form 2028 (Recommended Changes to Publications and Blank Forms), direct to: Commander, U.S. Army Tank-Automotive Command, Attn: AMSTA-MB, Warren, MI 48397-5000. A reply will be furnished to you.

1. **PURPOSE.** The installation of the kit contained in this MWO is intended to keep the NATO slave cable from disconnecting and dragging when the M983 HEMTT is towing the M860A1 trailer.
2. **PRIORITY.** This modification is classified as NORMAL.
3. **END ITEM TO BE MODIFIED.** Refer to Table 1.

TABLE 1. End Items to be Modified

Nomenclature	NSN	PN	CAGE	Model	Serial No. Range
Truck Tractor W/O Crane	2320-01-097-0247	XM983WOC	19207	M983	40126 and below

Approved for public release; distribution is unlimited.

Change 1

CHANGE
NO. 1

HEADQUARTERS
DEPARTMENT OF THE ARMY
Washington D.C., 1 November 1992

MODIFICATION WORK ORDER

**MODIFICATION OF M983 HEAVY EXPANDED MOBILITY
TACTICAL TRUCK (HEMTT) TRACTOR**

**INSTALLATION INSTRUCTIONS FOR
NATO SLAVE CABLE RETENTION DEVICE**

MODEL	NSN
TRUCK, TRACTOR, W/WINCH, W/O CRANE, M983	2320-01-097-0247

MWO 9-2320-279-20-8 dated 1 July 1992, is changed as follows:

1. Remove old pages and insert new pages as indicated below.
2. New or changed information is indicated by a vertical bar in the margin of the page.
3. Minor changes to illustrations are indicated by a miniature pointing hand.
4. Illustrations that are new or that have major revisions are indicated by a vertical bar adjacent to the illustration identification number.

Remove Pages
Cover and 2

Insert Pages
Cover and 2

3. File this change sheet in front of the publication for reference purposes.

APPROVED FOR PUBLIC RELEASE; DISTRIBUTION IS UNLIMITED

By Order of the Secretary of the Army:

GORDON R. SULLIVAN
General, United States Army
Chief of Staff

Official:

MILTON H. HAMILTON
Administrative Assistant to the
Secretary of the Army
03237

Distribution:

To be distributed in accordance with DA Form 12-38-E (Block 0868) Unit maintenance requirements for MWO 9-2320- 279-20-8.

- 4. **MODULE (COMPONENTS, ASSEMBLIES, SUBASSEMBLIES, BOARDS, AND CARDS) TO BE MODIFIED.**
Not applicable.
- 5. **PARTS TO BE MODIFIED.** The following items, whether installed or in depot stock shall be modified. Refer to table 2

TABLE 2. Parts to be Modified

NOMENCLATURE	NSN	PN	CAGE
Relay Assembly Hose Tenna	2540-01-293-8331	1533720U 27200	45152 52762

6. APPLICATION.

- a. Time Compliance Schedule. The effective date of this MWO is 1 June 1992 and its completion date is 30 May 1994.
- b. Lowest Level of Maintenance Authorized to Apply the MWO: Unit.
- c. Work Force and Man-Hour Requirements for Application of this MWO to a Single Unit, End Item or System is as follows:

REQUIREMENTS

WORK FORCE/SKILLS

MAN-HOURS

Heavy Wheeled Vehicle Mechanic
(MOS 63S) (1)

2.0

Total man-hours required for a single application of this MWO is two hours.

- d. MWO's to be applied to or Concurrently with the Application of this MWO: MWO 9-2320-279-20-3, Installation Instructions for NATO Slave Receptacle Relocation.
- e. Additional Information Deemed Necessary to Assist in the Application of this MWO. Not applicable.

7. TECHNICAL PUBLICATIONS AFFECTED/CHANGED. Refer to table 3

TABLE 3. Publications Affected

Publication	Date
TM 9-2320-279-10-1	November 1986
TM 9-2320-279-20-1	April 1987
TM 9-2320-279-20-2	April 1987
TM 9-2320-279-20P	March 1988
TM 9-2320-279-34P	March 1988

*U.S. GOVERNMENT PRINTING OFFICE : 1994 0 - 300-421 (03170)

8. MWO KITS/PARTS AND THEIR DISPOSITION.

a. Kits/Parts Needed to Apply this MWO.

(1) The parts listed in table 4 are required to accomplish this MWO.

TABLE 4. Part and Security Classification

Nomenclature	NSN	PN	CAGE	Qty	Classification
NATO Slave Retention Kit	2590-01-316-5826	1719050 U	45152	1	Unclassified
Includes:					
Base, Slave Cable Retention		1718860	45152	1	Unclassified
Arm, Slave Cable Retention		1718850	45152	1	Unclassified
Spring, Torsional		1718840	45152	1	Unclassified
Screw, Cap, Hex Head .31-18 X 4.25		55682AX	45152	1	Unclassified
Nut, Self locking .31-18		69034AX	45152	1	Unclassified
Hook, Slave Cable Support		1718830	45152	6	Unclassified
Nut, Plain Hex .31-18		369AX1	45152	13	Unclassified
Washer, Plain .31		1804HX	45152	14	Unclassified
Washer, Lock .31		354AX	45152	7	Unclassified
Hose 7"		1331980	45152	1	Unclassified
Spring Support		1718820	45152	1	Unclassified
Capscrew, Hex Head 31-18-1.25		737HX1	45152	1	Unclassified

(2) Kit shipping data: Weight 11lbs.
Volume 0.6 cu. ft.

- b. Contents of MWO Kits: Refer to table 4
- c. Bulk and Expendable Material: Not applicable.
- d. Parts Disposition: Not applicable.

9. SPECIAL TOOLS; JIGS; TEST MEASUREMENT AND DIAGNOSTIC EQUIPMENT (TMDE); AND FIXTURES REQUIRED. Not applicable.

10. MODIFICATION PROCEDURES.

- a. Prepare vehicle for installation of slave cable retention device.

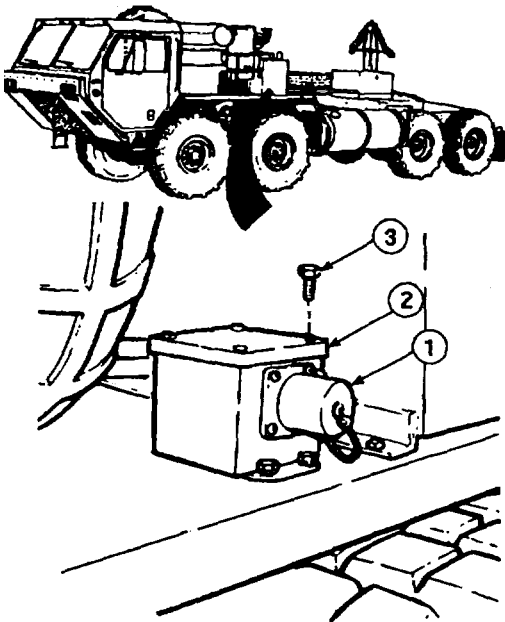

- (1) Remove cap (1) from NATO slave receptacle (2).
- (2) Remove four electrical box screws (3) from NATO slave receptacle (2).

- b. Assembling slave cable retention device.

- (1) Insert spring retainer end (1) into bracket hole (2).
- (2) Place opposite spring retainer end (3) under bracket retaining bolt hole end (4).

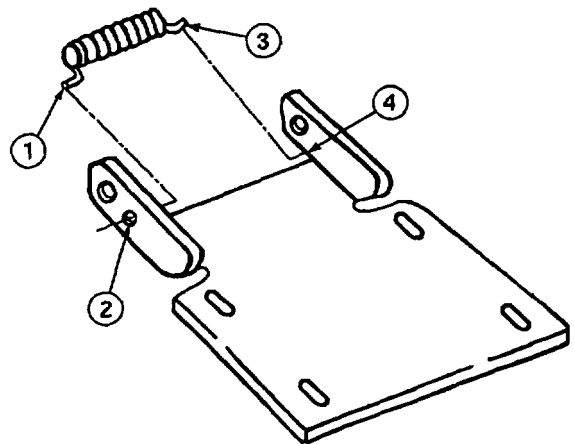

- (3) Insert spring retainer end (3) in bracket hole (5) and position bracket (6) in bracket (7).

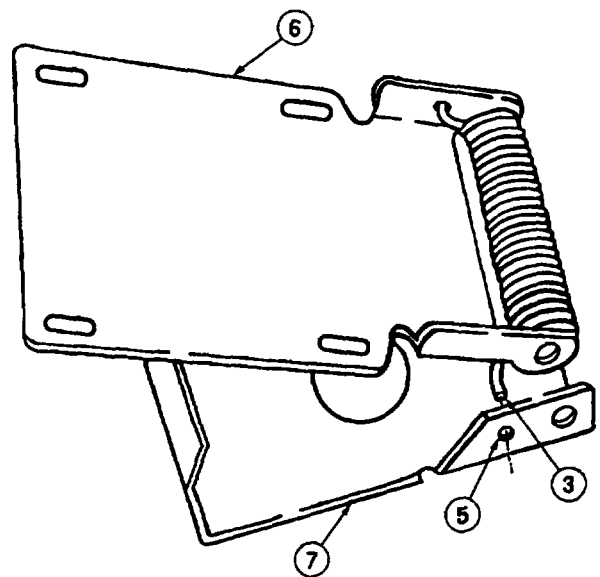

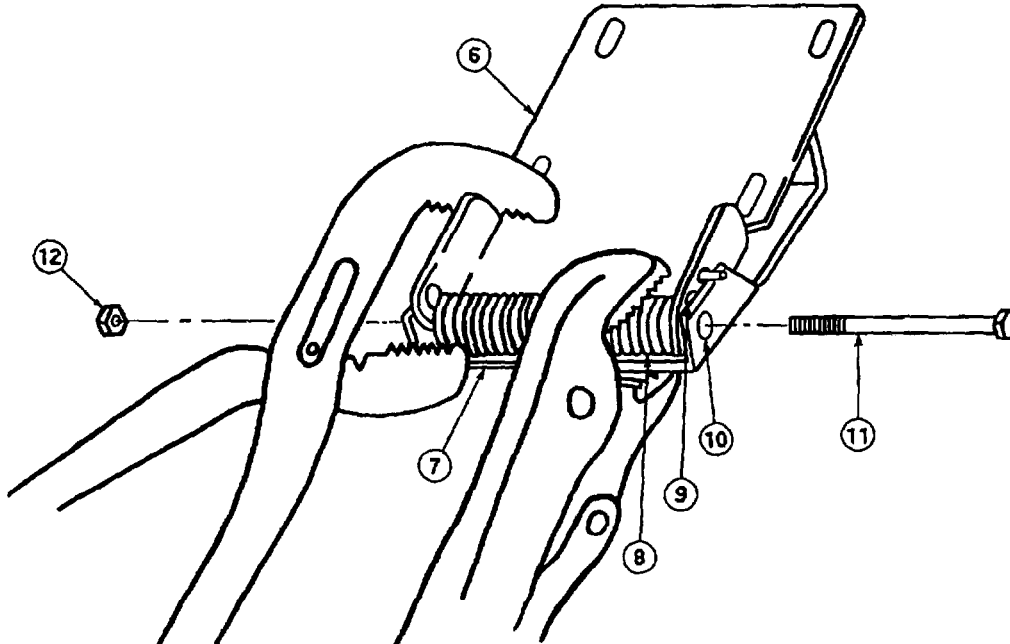

- (4) Using vise grips, compress spring (8) aligning bracket holes (9) and (10).
- (5) Insert cap screw (11) through holes (9) and (10) and spring (8).
- (6) Using channel locks, compress bracket (6) and bracket (7) until cap screw (11) slides through holes on opposite side.

- (7) Install locknut (12) on cap screw (11).
- (8) Install retention base (13) and secure with four screws (14).
- (9) Install NATO slave cap (15).

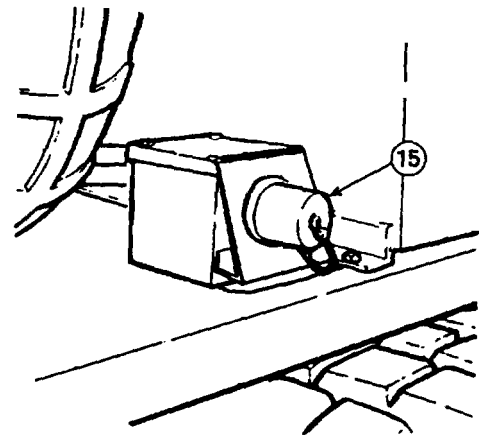
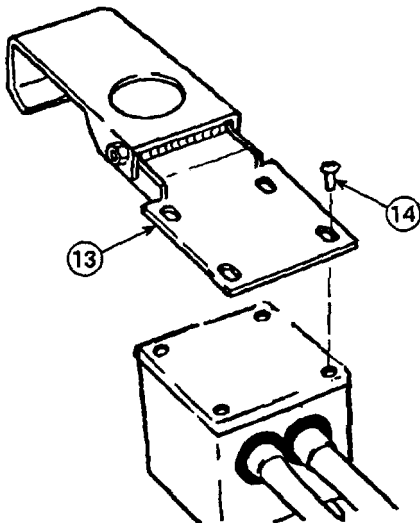

c. Install six slave cable support hooks.

NOTE

It may be necessary to remove expanded metal (grid) when drilling holes.

- (1) Drill two .34 inch diameter holes (1) and (2) as indicated.

NOTE

All hooks will be assembled and installed basically the same way. The position of the hooks may vary.

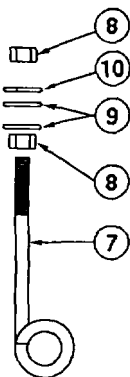

TYPICAL HOOK AND MOUNTING HARDWARE

- (2) Install nut (8) and flat washer (9) on hook (7). Insert hook (7) in drilled hole (1) and secure with flat washer (9), lockwasher (10) and nut (8). The loop of the hook (7) should be facing to the side and rear of the vehicle (approximately 450 angle) to allow installation and removal of the slave cable.

- (3) Insert hook (7) through underside of drilled hole (2). Make sure loop of hook is facing inward.

NOTE

If hooks are too large for existing holes in tool stowage box, ream out holes to .34 inch diameter.

- (4) Install nut (8) and flat washer (9) on two hooks (7). Insert hooks (7) in existing holes (3) and (4) located in bottom of tool stowage box. Secure hooks (7) with flat washer (9), lockwasher (10) and nut (8). The loop of the hooks (7) should be facing inward.

- (5) Drill two .34 inch diameter holes (5) and (6) as indicated.

- (6) Install nut (8) and flat washer (9) on two hooks (7). Insert hooks (7) in drilled holes (5) and (6) and secure with flat washer (9), lockwasher (10) and nut (8). The loop of the hooks (7) should be facing up.

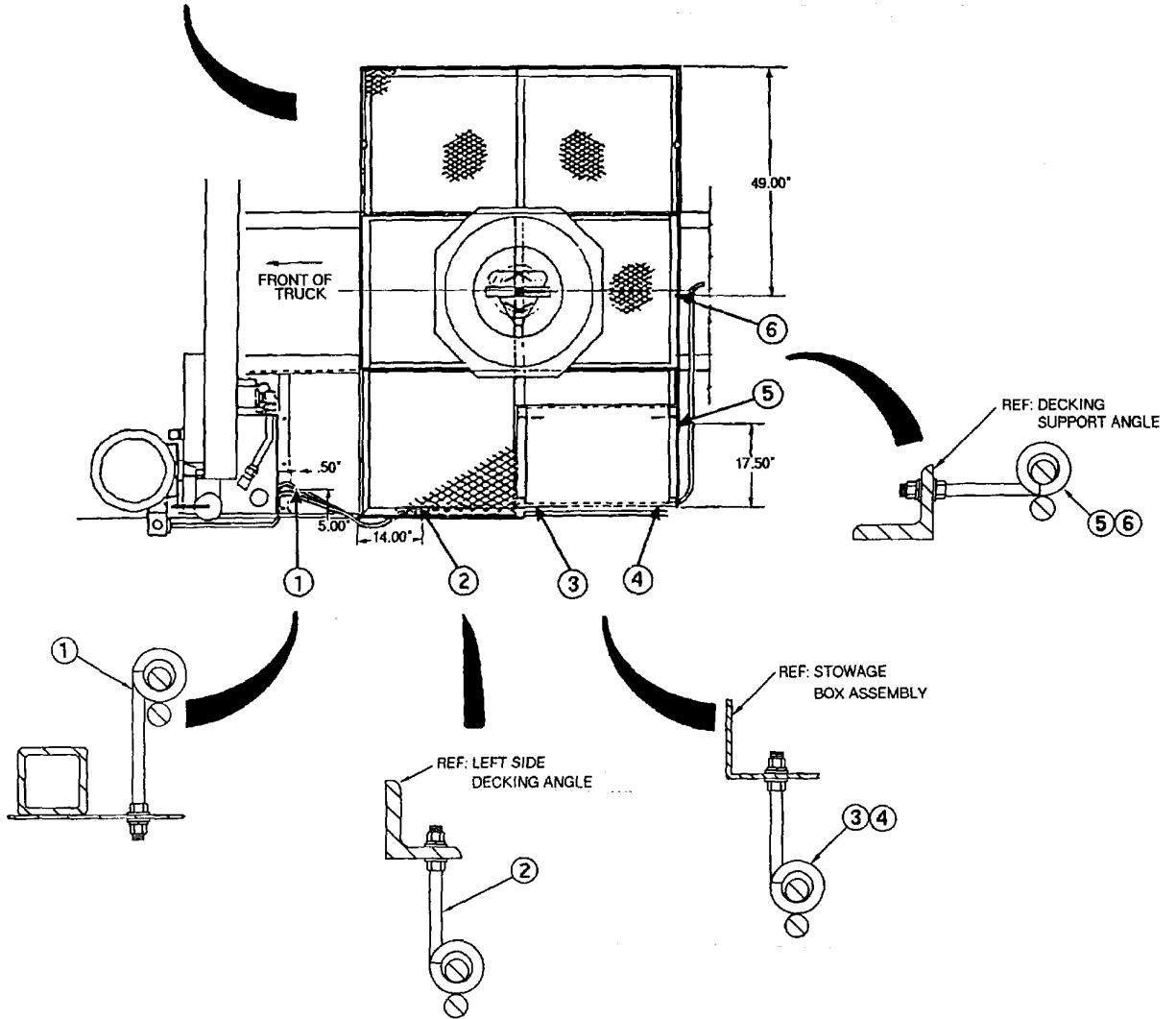
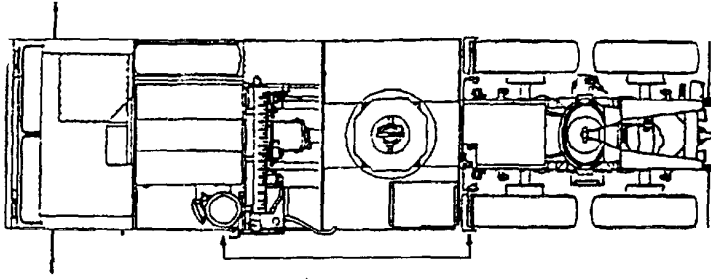

d. Modify hose tenna support.

- (1) Remove nut (1) and screw (2) from clamp (3) on hose tenna support (4).
- (2) Remove glad hands (5) from hose tenna support (4).
- (3) Remove two nuts (6), washers (7), and screws (8) from glad hand retainer bracket (9) on hose tenna support (4).
- (4) Remove nut (10), lockwasher (11), and washer (12) securing hose tenna support (4) to bracket (13) and remove hose tenna support (4).
- (5) Cut hose (17) to 6 1/2 inches and install onto hose tenna support (4).
- (6) Install spring (19) over hose tenna support (4).
- (7) Install hose tenna support (4) with spring (19), on bracket (13) and secure

with washer (12), lockwasher (11) and nut (10).

NOTE

Spring loop should be facing rear of vehicle prior to marking.

- (8) Mark center of loop. Rotate spring (19) and drill .34 inch diameter hole for spring hold down.
- (9) Secure spring (19) on bracket (13) with screw (18), flat washer (16), lockwasher (15) and locknut (14).
- (10) Install glad hand retainer bracket (9) to hose tenna support (4) and secure with two nuts (6), washers (7), and screws (8).
- (11) Install clamp (3) onto hose tenna support (4) and secure with nut (1) and screw (2).
- (12) Attach glad hands (5) to hose tenna support (4).

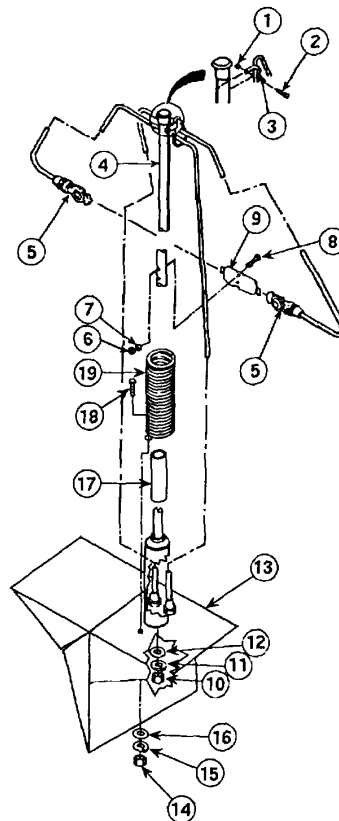
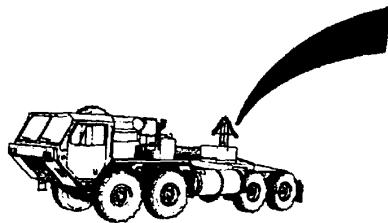

11. **CALIBRATION REQUIREMENTS.** Not applicable.
12. **WEIGHT AND BALANCE DATA.** Weight and balance are not significantly affected.
13. **QUALITY ASSURANCE REQUIREMENTS.**
 - a. Assure that all holes are marked and drilled as shown in Para 10c.
 - b. Assure that the slave cable retention base and arm are properly assembled.
 - c. Assure that all hooks and mounting hardware are properly installed and secured.
 - d. Inspect the total kit installation for completeness and assure kit is operable.
14. **RECORDING AND REPORTING OF THE MODIFICATION.**
 - a. Records and Reports: Record the modification in accordance with AR 750-10, DA PAM 738-750, DA PAM 738-751 and TB 9-1100-803-15.
 - b. Marking Equipment: Not applicable.
 - c. Identification Data: Not applicable.
15. **PRODUCT IMPROVEMENT PROPOSAL (PIP) NUMBER.** This MWO is authorized by PIP number 1-89-06-4243.
16. **MODIFICATION IDENTIFICATION.** Refer to paragraph 10. The clip will be visible on the slave receptacle, and hooks will be visible on the frame.

By Order of the Secretary of the Army:

Official:

MILTON H. HAMILTON
*Administrative Assistant to the
Secretary of the Army*
01955

GORDON R. SULLIVAN
*General, United States Army
Chief of Staff*

Distribution:

To be distributed in accordance with DA Form 12-38-E (Block 0868) Unit maintenance requirements for MW09-2320-279-20-8.

* U.S. GOVERNMENT PRINTING OFFICE: 1992 643016/60125

RECOMMENDED CHANGES TO EQUIPMENT TECHNICAL PUBLICATIONS



THEN... JOT DOWN THE DOPE ABOUT IT ON THIS FORM, CAREFULLY TEAR IT OUT, FOLD IT AND DROP IT IN THE MAIL!

SOMETHING WRONG WITH THIS PUBLICATION?

FROM: (PRINT YOUR UNIT'S COMPLETE ADDRESS)

DATE SENT

PUBLICATION NUMBER

PUBLICATION DATE

PUBLICATION TITLE

BE EXACT... PIN-POINT WHERE IT IS

IN THIS SPACE TELL WHAT IS WRONG AND WHAT SHOULD BE DONE ABOUT IT:

PAGE NO.	PARA-GRAPH	FIGURE NO.	TABLE NO.
----------	------------	------------	-----------

TEAR ALONG PERFORATED LINE

PRINTED NAME, GRADE OR TITLE, AND TELEPHONE NUMBER

SIGN HERE:

DA FORM 2028-2 JUL 79

PREVIOUS EDITIONS ARE OBSOLETE.

P.S.—IF YOUR OUTFIT WANTS TO KNOW ABOUT YOUR RECOMMENDATION MAKE A CARBON COPY OF THIS AND GIVE IT TO YOUR HEADQUARTERS.

THE METRIC SYSTEM AND EQUIVALENTS

WEIGHT MEASURE

1 Centimeter = 10 Millimeters = 0.01 Meters = 0.3937 Inches
 1 Meter = 100 Centimeters = 1000 Millimeters = 39.37 Inches
 1 Kilometer = 1000 Meters = 0.621 Miles

WEIGHTS

1 Gram = 0.001 Kilograms = 1000 Milligrams = 0.035 Ounces
 1 Kilogram = 1000 Grams = 2.2 lb.
 1 Metric Ton = 1000 Kilograms = 1 Megagram = 1.1 Short Tons

LIQUID MEASURE

1 Milliliter = 0.001 Liters = 0.0338 Fluid Ounces
 1 Liter = 1000 Milliliters = 33.82 Fluid Ounces

SQUARE MEASURE

1 Sq. Centimeter = 100 Sq. Millimeters = 0.155 Sq. Inches
 1 Sq. Meter = 10,000 Sq. Centimeters = 10.76 Sq. Feet
 1 Sq. Kilometer = 1,000,000 Sq. Meters = 0.386 Sq. Miles

CUBIC MEASURE

1 Cu. Centimeter = 1000 Cu. Millimeters = 0.06 Cu. Inches
 1 Cu. Meter = 1,000,000 Cu. Centimeters = 35.31 Cu. Feet

TEMPERATURE

$5/9(^{\circ}\text{F} - 32) = ^{\circ}\text{C}$
 212° Fahrenheit is equivalent to 100° Celsius
 90° Fahrenheit is equivalent to 32.2° Celsius
 32° Fahrenheit is equivalent to 0° Celsius
 $9/5^{\circ}\text{C} + 32 = ^{\circ}\text{F}$

APPROXIMATE CONVERSION FACTORS

TO CHANGE	TO	MULTIPLY BY
Inches	Centimeters	2.540
Feet	Meters	0.305
Yards	Meters	0.914
Miles	Kilometers	1.609
Square Inches	Square Centimeters	6.451
Square Feet	Square Meters	0.093
Square Yards	Square Meters	0.836
Square Miles	Square Kilometers	2.590
Acres	Square Hectometers	0.405
Cubic Feet	Cubic Meters	0.028
Cubic Yards	Cubic Meters	0.765
Fluid Ounces	Milliliters	29.573
its	Liters	0.473
arts	Liters	0.946
allons	Liters	3.785
Ounces	Grams	28.349
Pounds	Kilograms	0.454
Short Tons	Metric Tons	0.907
Pound-Feet	Newton-Meters	1.356
Pounds per Square Inch	Kilopascals	6.895
Miles per Gallon	Kilometers per Liter	0.425
Miles per Hour	Kilometers per Hour	1.609

TO CHANGE	TO	MULTIPLY BY
Centimeters	Inches	0.394
Meters	Feet	3.280
Meters	Yards	1.094
Kilometers	Miles	0.621
Square Centimeters	Square Inches	0.155
Square Meters	Square Feet	10.764
Square Meters	Square Yards	1.196
Square Kilometers	Square Miles	0.386
Square Hectometers	Acres	2.471
Cubic Meters	Cubic Feet	35.315
Cubic Meters	Cubic Yards	1.308
Milliliters	Fluid Ounces	0.034
Liters	Pints	2.113
Liters	Quarts	1.057
ers	Gallons	0.264
ms	Ounces	0.035
ograms	Pounds	2.205
Metric Tons	Short Tons	1.102
Newton-Meters	Pounds-Feet	0.738
Kilopascals	Pounds per Square Inch	0.145
ometers per Liter	Miles per Gallon	2.354
ometers per Hour	Miles per Hour	0.621

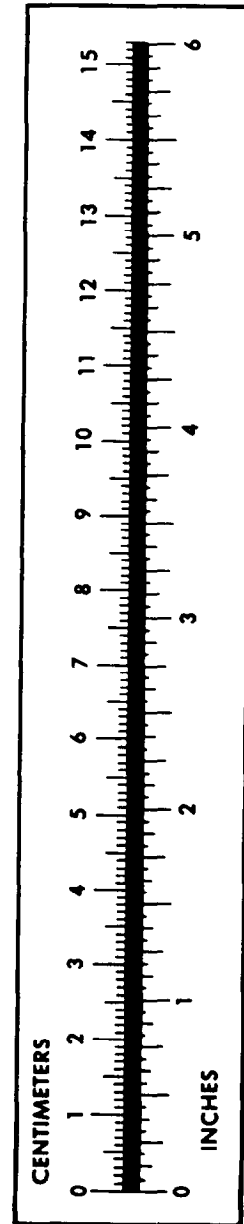

PIN: 070094-001